

Machine Dimensions and Specifications

Model SYN090



Equipment specifications are subject to change without notice.

Dimensions and Foundation Requirements

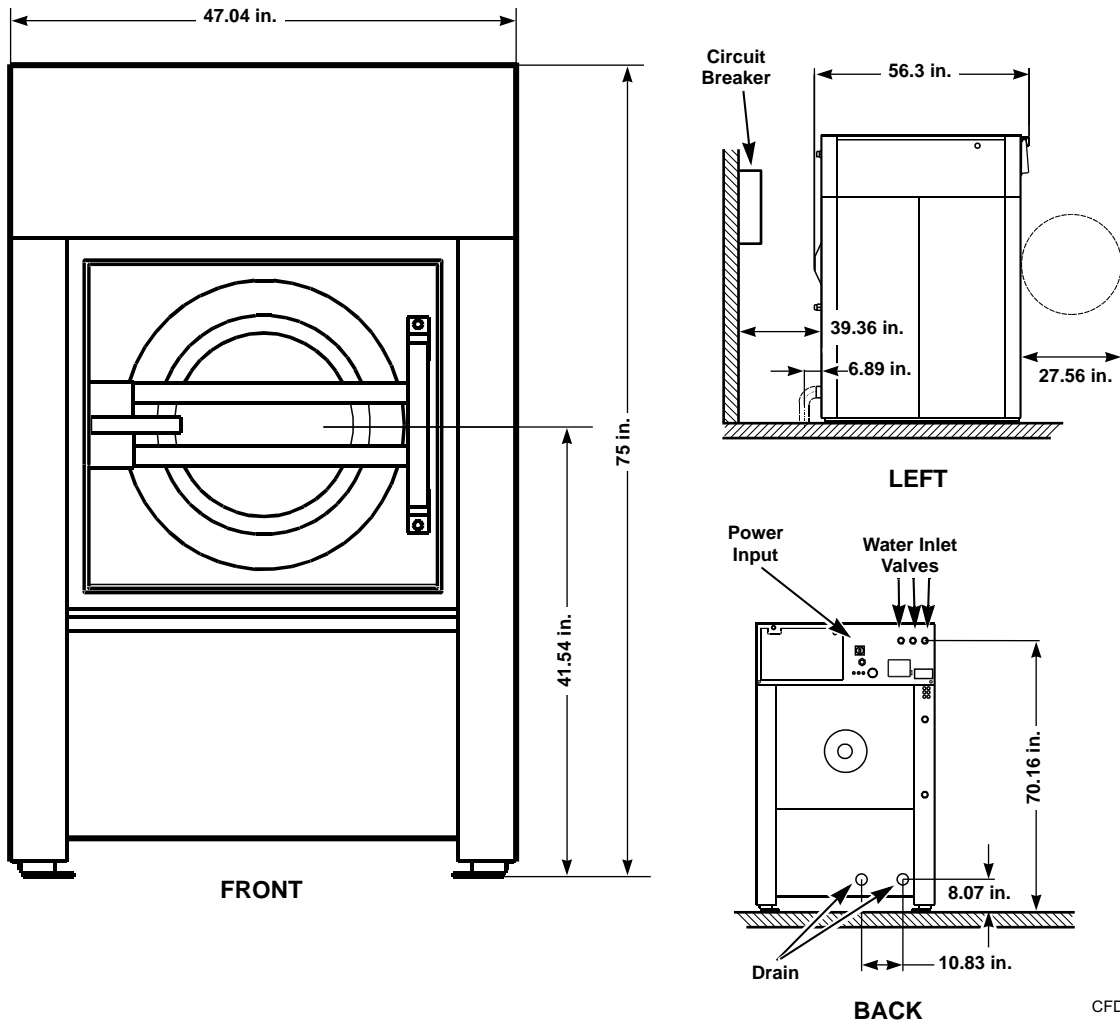

CFD3L

Electrical Specifications

Voltage Designation					Non-Electric Heat Machines (Standard)		
Code	Voltage	Cycle	Phase	Wire	Full Load Amps	Breaker (Non Fused)	AWG
Q	208-240	60	3	3 (L1, L2, L3)	25.4	40	9
N	440-480	60	3	3 (L1, L2, L3)	14.6	20	13

Water, Drain and Weight Specifications

Drain: Number (Size)	2 (3 in.)
Fill Water Inlets: Number (Size)	3 (1 in.)
Weight: Machine (With Shipping Packaging)	3439 lbs. (3748 lbs.)
Left Side Clearance:	24.5 in. (minimum) 27.55 in. (recommended)
Right Side Clearance	10 in. (minimum) 27.55 in. (recommended)